

**UNIVERSITY OF SWAZILAND**

**FACULTY OF EDUCATION**

**DEPARTMENT OF CURRICULUM AND TEACHING**

**FINAL EXAMINATION QUESTION PAPER, MAY 2010**

**TITLE OF PAPER : CURRICULUM STUDIES IN BIOLOGY II**

**COURSE CODE : EDC 378**

**STUDENTS : B.Ed III, PGCE**

**TIME ALLOWED : THREE (3) HOURS**

**INSRTUCTIONS: 1. This question paper has six (6) questions. Answer four (4) questions only**

**2. Each question has a total of 25 points. The number of points for each sub-question, where it exists, is indicated in parentheses**

**3. There is an attachment for one question**

**THIS PAPER IS NOT TO BE OPENED UNTIL PERMISSION HAS BEEN GRANTED BY THE INVIGILATOR**

1. a) Swaziland is a consumer rather than a producer of science and technology. Explain why science, technology and society issues should be included in the science curriculum in Swazi schools. [10]
- b) The launching of Sputnik 1 drastically changed the science curriculum in Western countries and their colonies. Discuss the impact of these curricula on the state of science education in the post sputnik era. [15]
2. a) Compare and contrast the goals of the Forum for African Women Educationalists (FAWE) and Female Education in Mathematics and Science in Africa (FEMSA) with regards to girls' education in Africa. [5]
- b) There is very little disparity, if any, in the number of girls and boys in the school system in Swaziland when compared to other African countries. Explain why Swaziland should be concerned about girls' education given the current state of affairs. [20]
3. a) A contextualised science curriculum in which the content reflects the students' everyday experiences is now being emphasised for schools in Swaziland. Outline the steps you would take to develop a relevant and affordable science curriculum for a rural secondary school in Swaziland. Include considerations you would make to plan, design, implement and evaluate your curriculum. [15]
- b) Explain how you would use the following resources to teach a topic on cell structure and function in a rural school in Swaziland [10]

Overhead projector/transparency

Charts

Textbooks/workbooks

4. a) Explain how the following help us to understand children's ability to learn science
  - i) Constructivist theory
  - ii) Bruner's theory
  - iii) Ausubel's theory
  - iv) Piaget's theory [16]
- b) Explain the role of the following in assisting meaningful learning
  - i) prior concepts
  - ii) subsumer
  - iii) advance organizer [9]

5. a) Describe the factors that affect interaction between sensory information and Short Term Memory which may interfere with learners' acquisition of science concepts. [15]
- b) Learning in science involves the use of many scientific words and concepts. Describe how you would teach Form I science students the concept of photosynthesis such that they are able to construct their own definition. [10]
6. Attached is a unit on the topic Cells and Tissues for Form IV Biology. Select a section(s) and use it to construct a concept map that clearly illustrates the structure and function of cells and the relationships among the concepts which reflect the knowledge structure you wish your learners to acquire in this domain of knowledge.  
The construction process should show the following steps:
1. Identify and list the key concepts [5]
  2. Rank concepts according to their level of generality or specificity [5]
  3. Cluster concepts that interrelate closely [3]
  4. Arrange concepts in a two dimensional array or hierarchical representation [7]
  5. Link related concepts and label with appropriate descriptors [5]

# 1

# Cells and tissues

## Cell structure

How tissues are studied to see cells: taking sections. Cell components: Plant cells.

## Cell division and cell specialization

Cell division and growth. Specialization of cells for different functions.

## Tissues and organs

Definitions and examples of tissues, organs and systems.

## Practical work

Preparing, observing and drawing plant and animal cells

## Cell structure

If a very thin slice of a plant stem is cut and studied under a microscope, it can be seen that the stem consists of thousands of tiny, box-like structures. These structures are called **cells**. Figure 1.1 is a thin slice taken from the tip of a plant shoot and photographed through a microscope. Photographs like this are called **photomicrographs**. The one in Figure 1.1 is 60 times larger than life, so a cell which appears to be 2 mm long in the picture is only 0.03 mm long in life.

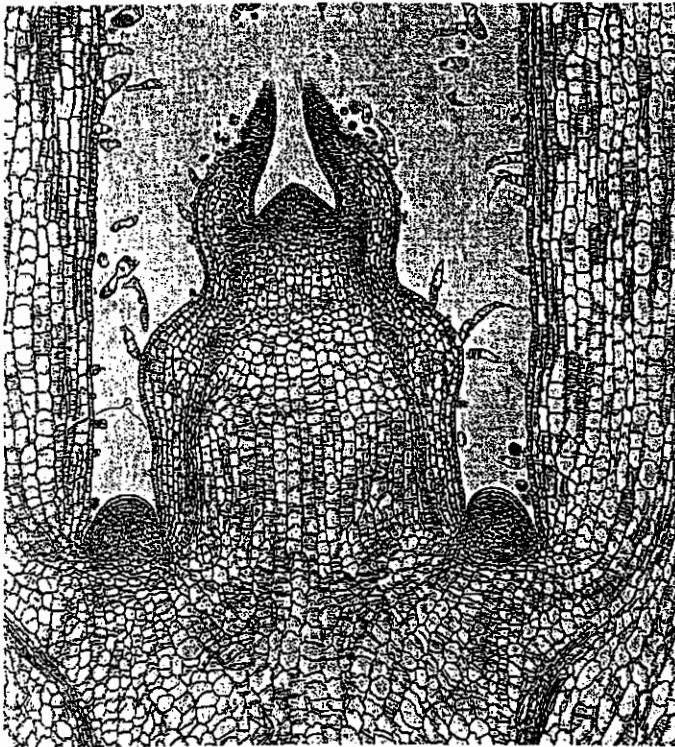
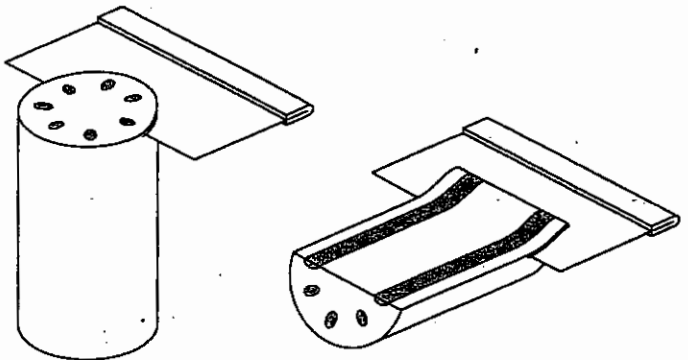


Figure 1.1 Longitudinal section through the tip of a plant shoot ( $\times 60$ ). The slice is only one cell thick, so light can pass through it and allow the cells to be seen clearly

Thin slices of this kind are called **sections**. If you cut *along the length* of the structure, you are taking a **longitudinal section** (Figure 1.2b). Figure 1.1 shows a longitudinal section, which passes through two small

developing leaves near the tip of the shoot, and two larger leaves below them. The leaves, buds and stem are all made up of cells. If you cut *across* the structure, you make a **transverse section** (Figure 1.2a).



(a) transverse section

(b) longitudinal section

Figure 1.2 Cutting sections of a plant stem

It is fairly easy to cut sections through plant structures just by using a razor blade. To cut sections of animal structures is more difficult because they are mostly soft and flexible. Pieces of skin, muscle or liver, for example, first have to be soaked in melted wax. When the wax goes solid it is then possible to cut thin sections. The wax is dissolved away after making the section.

When sections of animal structures are examined under the microscope, they, too, are seen to be made up of cells but they are much smaller than plant cells and need to be magnified more. The photomicrograph of kidney tissue in Figure 1.3 has been magnified 700 times to show the cells clearly. The sections are often treated with dyes, called 'stains', in order to show up the structures inside the cells more clearly.

Making sections is not the only way to study cells. Thin strips of plant tissue, only one cell thick, can be pulled off stems or leaves (Experiment 1, p. 9). Plant or animal tissue can be squashed or smeared on a microscope slide (Experiment 2, p. 10) or treated with chemicals to separate the cells before studying them.

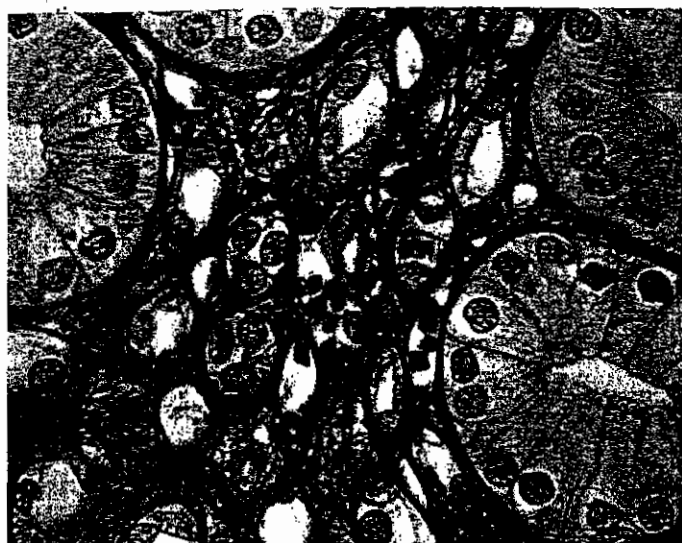


Figure 1.3 Transverse section through a kidney tubule ( $\times 700$ ). A section through a tube will look like a ring (see Figure 1.12b on p. 7). In this case, each 'ring' consists of about 12 cells

There is no such thing as a typical plant or animal cell because cells vary a great deal in their size and shape depending on their function. Nevertheless, it is possible to make a drawing like Figure 1.4 to show features which are present in most cells. *All cells* have a **cell membrane**, which is a thin boundary enclosing the **cytoplasm**. Most cells have a **nucleus**.

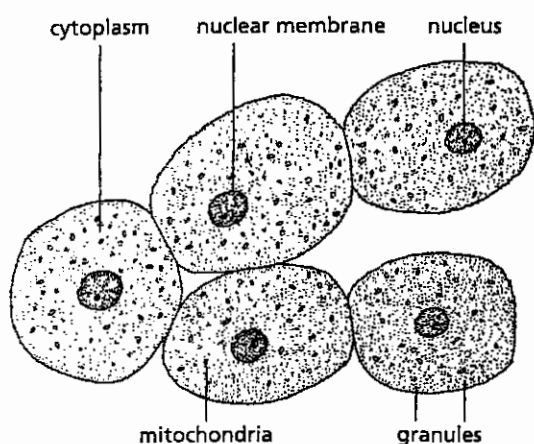


Figure 1.4 A group of liver cells. These cells have all the characteristics of animal cells

### Cytoplasm

Under the ordinary microscope (light microscope), cytoplasm looks like a thick liquid with particles in it. In plant cells it may be seen to be flowing about. The particles may be food reserves such as oil droplets or granules of starch. Other particles are structures which have particular functions in the cytoplasm. These structures are the **organelles**. Examples are the **ribosomes**, which build up the cell's proteins (see p. 11) and the **mitochondria**, which generate energy for the cell's living processes (see p. 20).

When studied at much higher magnifications with the **electron microscope**, the cytoplasm no longer looks like a structureless jelly but appears to be organized into a complex system of membranes and vacuoles.

In the cytoplasm, a great many chemical reactions are taking place which keep the cell alive by providing energy and making substances that the cell needs (see pp. 11 and 20).

The liquid part of cytoplasm is about 90 per cent water with molecules of salts and sugars dissolved in it. Suspended in this solution there are larger molecules of fats (lipids) and proteins (see pp. 11–12). Lipids and proteins may be used to build up the cell structures, e.g. the membranes. Some of the proteins are **enzymes** (p. 14). Enzymes control the rate and type of chemical reactions which take place in the cells. Some enzymes are attached to the membrane systems of the cell, whereas others float freely in the liquid part of the cytoplasm.

### Cell membrane

This is a thin layer of cytoplasm round the outside of the cell. It stops the cell contents from escaping and also controls the substances which are allowed to enter and leave the cell. In general, oxygen, food and water are allowed to enter; waste products are allowed to leave and harmful substances are kept out. In this way the cell membrane maintains the structure and chemical reactions of the cytoplasm.

### Nucleus (plural = nuclei)

Most cells contain one nucleus, which is usually seen as a rounded structure enclosed in a membrane and embedded in the cytoplasm. In drawings of cells, the nucleus may be shown darker than the cytoplasm because, in prepared sections, it takes up certain stains more strongly than the cytoplasm. The function of the nucleus is to control the type and quantity of enzymes produced by the cytoplasm. In this way it regulates the chemical changes which take place in the cell. As a result, the nucleus determines what the cell will be, e.g. a blood cell, a liver cell, a muscle cell or a nerve cell.

The nucleus also controls cell division as shown in Figure 1.8 on p. 5. A cell without a nucleus cannot reproduce. Inside the nucleus are thread-like structures called **chromosomes**, which can be seen most easily at the time when the cell is dividing. (See p. 182 for a fuller account of chromosomes.)

### Mitochondria

The mitochondria are tiny organelles present in plant and animal cells. They may be spherical, rod-like or elongated. They are most numerous in regions of rapid chemical activity and are responsible for producing energy from food substances (see 'Respiration', p. 19).

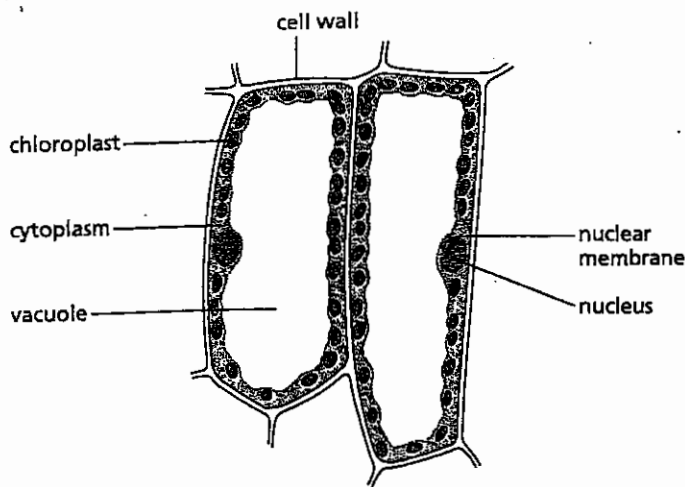


Figure 1.5 Palisade cells from a leaf

## Plant cells

A few generalized animal cells are represented by Figure 1.4, while Figure 1.5 is a drawing of two palisade cells from a plant leaf (see pp. 51 and 53).

Plant cells differ from animal cells in several ways:

- 1 Outside the cell membrane they all have a **cell wall** which contains cellulose and other compounds. It is non-living and allows water and dissolved substances to pass through. The cell wall is not selective like the cell membrane. (Note that plant cells *do* have a cell membrane but it is not easy to see or draw because it is pressed against the inside of the cell wall. See Figure 1.6.)

Under the microscope, plant cells are quite distinct and easy to see because of their cell walls. In Figure 1.1 it is only the cell walls (and in some cases the nuclei) which can be seen. Each plant cell has its own cell wall but the boundary between two cells side by side does not usually show up clearly. Cells next to each other therefore appear to be sharing the same cell wall.

- 2 Most mature plant cells have a large, fluid-filled space called a **vacuole**. The vacuole contains **cell sap**, a watery solution of sugars, salts and sometimes pigments. This large, central vacuole pushes the cytoplasm aside so that it forms just a thin lining inside the cell wall. It is the outward pressure of the vacuole on the cytoplasm and cell wall which makes plant cells and their tissues firm (see p. 30). Animal cells may sometimes have small vacuoles in their cytoplasm but they are usually produced to do a particular job and are not permanent.
- 3 In the cytoplasm of plant cells are many organelles called **plastids** which are not present in animal cells. If they contain the green substance **chlorophyll**, the organelles are called **chloroplasts** (see p.38). Colourless plastids usually contain starch, which is used as a food store.

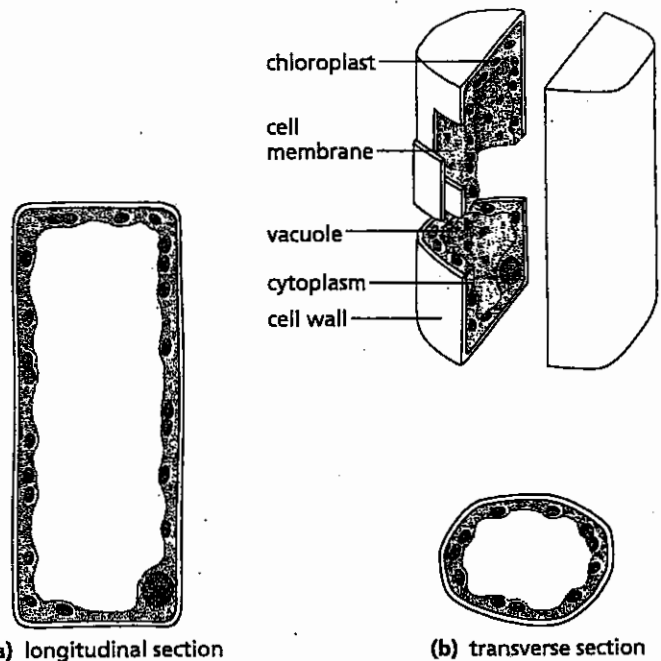


Figure 1.6 Structure of a palisade cell. It is important to remember that, although cells look flat in sections or in thin strips of tissue, they are in fact three-dimensional and may seem to have different shapes according to the direction in which the section is cut. If the cell is cut across it will look like (b); if cut longitudinally it will look like (a)

The shape of a cell when seen in a transverse section may be quite different when the same cell is seen in a longitudinal section and Figure 1.6 shows why this is so. Figures 6.10b and 6.10c on p.55 show the appearance of cells in a stem vein as seen in transverse and longitudinal section.

## Questions

- 1 a What structures are usually present in all cells, whether they are from an animal or from a plant?  
b What structures are present in plant cells but not in animal cells?
- 2 What cell structure is largely responsible for controlling the entry and exit of substances into or out of the cell?
- 3 In what way does the red blood cell shown in Figure 12.1 on p.108 differ from most other animal cells?
- 4 How does a cell membrane differ from a cell wall?
- 5 Why does the cell shown in Figure 1.6b appear to have no nucleus?
- 6 a In order to see cells clearly in a section of plant tissue, would you have to magnify the tissue?  
(i)  $\times 5$   
(ii)  $\times 10$   
(iii)  $\times 100$  or  
(iv)  $\times 1000$ ?  
b What is the approximate width (in mm) of one of the largest cells in Figure 1.32?
- 7 In Figure 1.3, the cell membranes are not always clear. Why is it still possible to decide roughly how many cells there are in each tubule section?

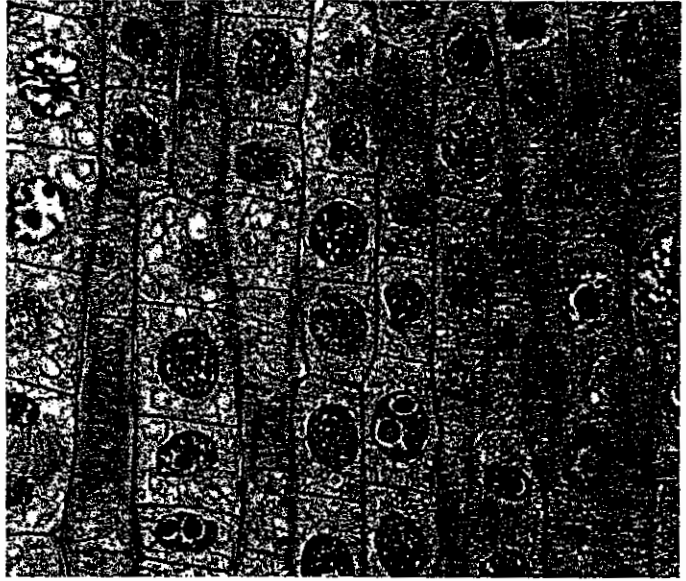
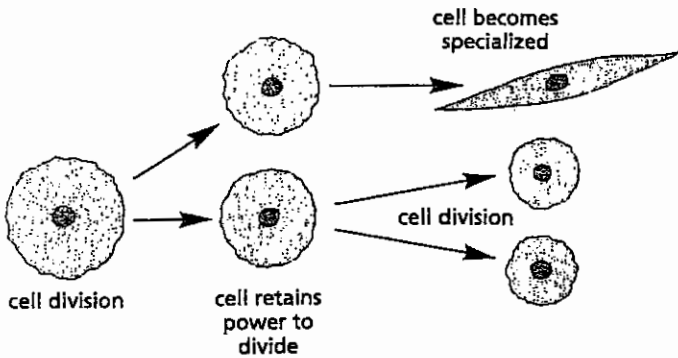
## Cell division and cell specialization

### Cell division

When plants and animals grow, their cells increase in number by dividing. Typical growing regions are the ends of bones, layers of cells in the skin, root tips and buds (Figure 1.10). Each cell divides to produce two daughter cells. Both daughter cells may divide again, but usually one of the cells grows and changes its shape and structure and becomes adapted to do one particular job – in other words, it becomes **specialized** (Figure 1.7). At the same time it loses its ability to divide any more. The other cell is still able to divide and so continue the growth of the tissue. **Growth** is, therefore, the result of cell division, followed by cell enlargement and, in many cases, cell specialization.

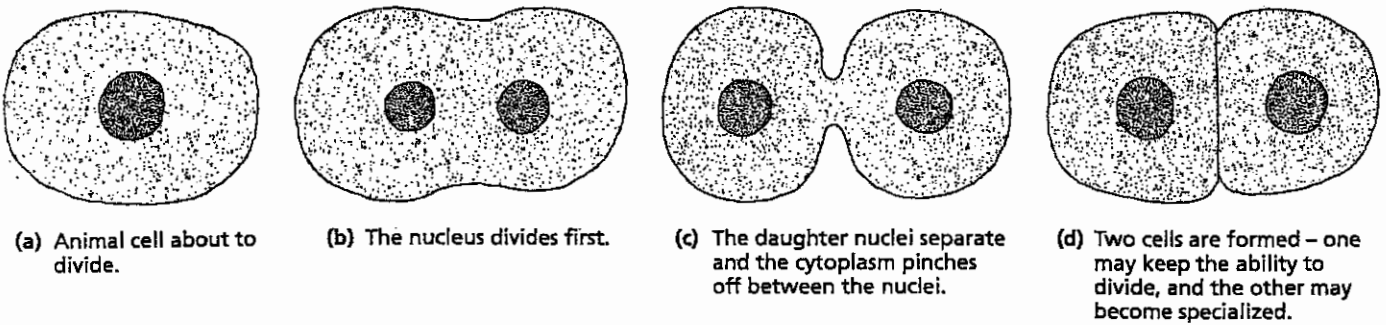
The process of cell division in an animal cell is shown in Figure 1.8. The events in a plant cell are shown in Figures 1.9 and 1.10. Because of the cell wall, the cytoplasm cannot simply pinch off in the middle, and a new wall has to be laid down between the two daughter cells. Also a new vacuole has to form.

Organelles such as mitochondria and chloroplasts are able to divide and are shared more or less equally between the daughter cells at cell division.

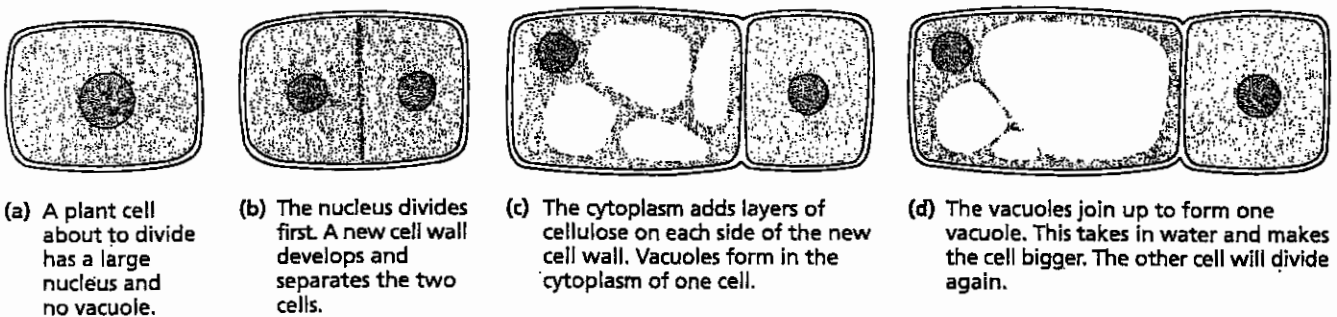


**Figure 1.10** Cell division in an onion root tip ( $\times 300$ ). The nuclei are stained blue. Most of the cells have just completed cell division

**Figure 1.7** Cell division and specialization. Cells which retain the ability to divide are sometimes called **stem cells**



**Figure 1.8** Cell division in an animal cell



**Figure 1.9** Cell division in a plant cell

## Specialization of cells

Most cells, when they have finished dividing and growing, become specialized (Figure 1.11). This means that:

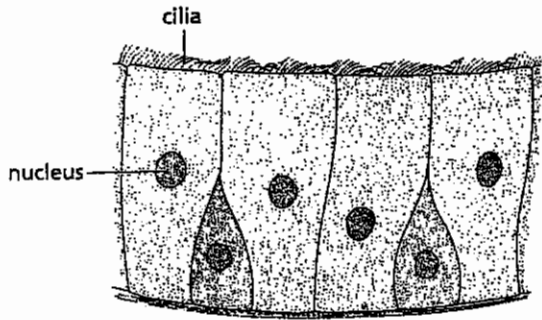
- They do one particular job.
- They develop a distinct shape.
- Special kinds of chemical change take place in their cytoplasm. The changes in shape and chemical reactions enable the cell to carry out its special function. Nerve cells and guard cells are examples of specialized cells.

Nerve cells (Figure 1.11e):

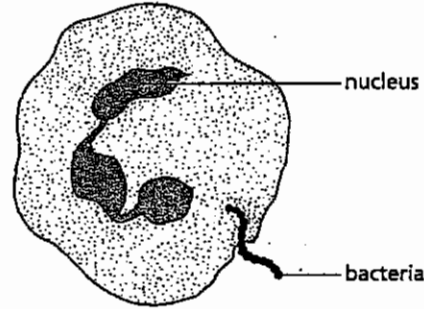
- Conduct electrical impulses to and from the brain.
- Some of them are very long and connect distant parts of the body to the spinal cord and brain.
- Their chemical reactions cause the impulses to travel along the fibre.

Root hair cells (Figure 1.11d):

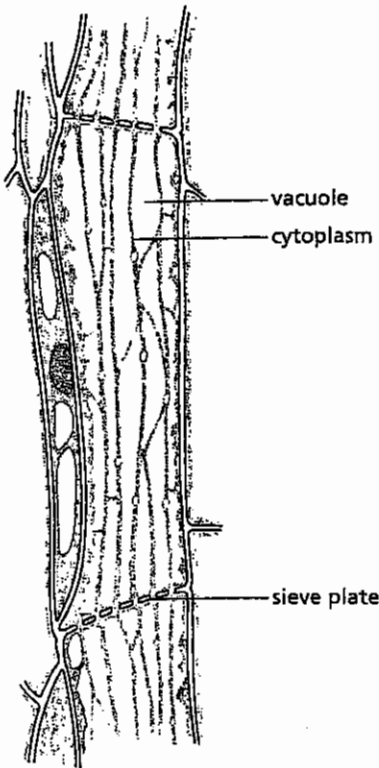
- Absorb water and mineral salts from the soil.
- The hair-like projection penetrates between the soil particles and offers a large absorbing surface.
- The cell membrane is able to control which dissolved substances enter the cell.



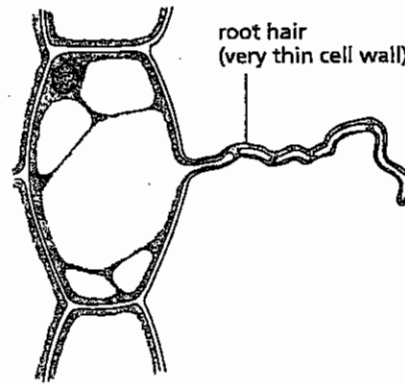
(a) ciliated cells  
These form the lining of the nose and windpipe, and the tiny cytoplasmic 'hairs', called cilia, are in a continually flicking movement keeping up a stream of fluid (mucus) that carries dust and bacteria away from the lungs.



(b) white blood cell  
Occurs in the bloodstream and is specialized for engulfing harmful bacteria. It is able to change its shape and move about, even through the walls of blood vessels into the surrounding tissues.

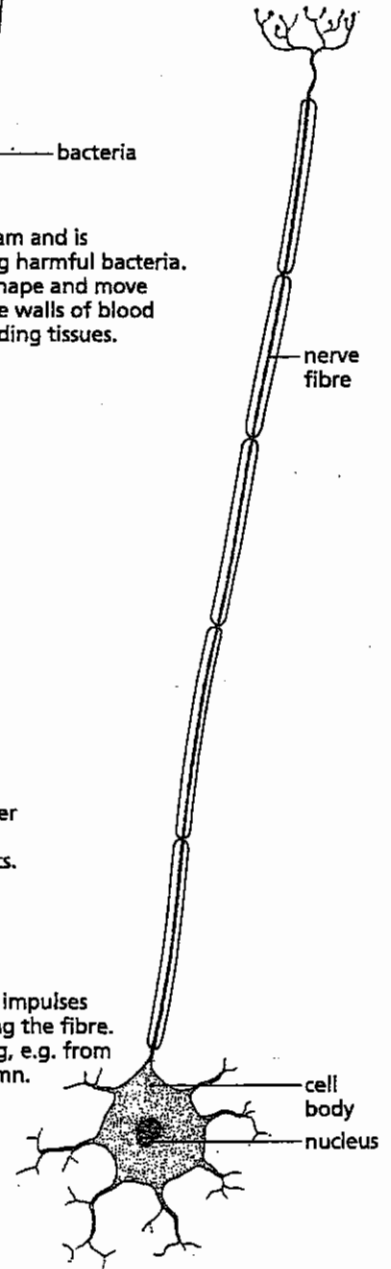


(c) food-conducting cell in a plant (phloem cell)  
Long cells, joined end to end, and where they meet, perforations occur in the walls. Through these holes the cytoplasm of one cell communicates with the next. Dissolved food is thought to pass through the holes during its transport through the stem.



(d) root hair cell  
These cells, in their thousands, form the outer layer of young roots and present a vast surface for absorbing water and mineral salts. (See Figures 6.14, 7.6 on pp. 57, 63.)

(e) nerve cell  
Specialized for conducting impulses of an electrical nature along the fibre. The fibres may be very long, e.g. from the foot to the spinal column.



6 Figure 1.11 Specialized cells (not to scale)



The specialization of cells to carry out particular functions in an organism is sometimes referred to as 'division of labour' within the organism. Similarly, the special functions of mitochondria, ribosomes and other cell organelles may be termed 'division of labour' within the cell.

## Questions

- Select from the following events and put them in the correct order for cell division in
  - animal cells,
  - plant cells:
    - cytoplasm divides,
    - vacuole forms in one cell,
    - new cell wall separates cells,
    - nucleus divides.
- Look at Figure 6.2 on p. 51.
  - Whereabouts in a leaf are the food-carrying cells?
  - What other specialized cells are there in the leaf?

## Tissues and organs

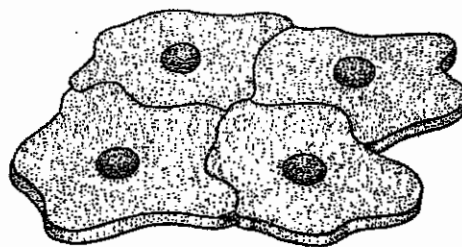
There are some microscopic organisms that consist of one cell only and can carry out all the processes necessary for their survival (see p. 268). The cells of the larger plants and animals cannot survive on their own. A muscle cell could not obtain its own food and oxygen. Other specialized cells have to provide the food and oxygen needed for the muscle cell to live. Unless these cells are grouped together in large numbers and made to work together, they cannot exist for long.

### Tissues

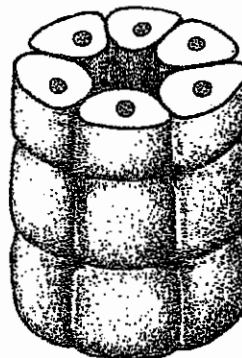
A tissue such as bone, nerve or muscle in animals, and epidermis, phloem or pith (p. 54) in plants, is made up of many hundreds of cells of a few types. The cells of each type have similar structures and functions so that the tissue itself can be said to have a particular function, e.g. nerves conduct impulses, phloem carries food in plants. Figure 1.12 shows how some cells are arranged to form simple tissues.

### Organs

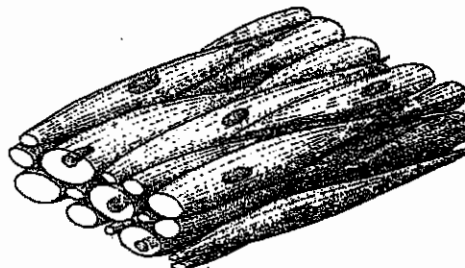
Organs consist of several tissues grouped together to make a structure with a special function. For example, the stomach is an organ which contains tissues made from epithelial cells, gland cells and muscle cells. These cells are supplied with food and oxygen brought by blood vessels. The stomach also has a nerve supply. The heart, lungs, intestines, brain and eyes are further examples of organs in animals. In flowering plants, the root, stem and leaves are the organs. The tissues of the leaf are epidermis, palisade tissue, spongy tissue, xylem and phloem (see pp. 39 and 50-3).



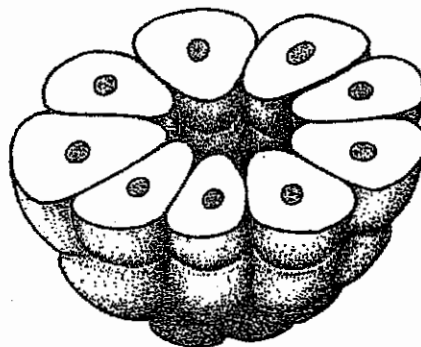
- (a) cells forming an epithelium  
A thin layer of tissue, e.g. the lining of the mouth cavity. Different types of epithelium form the internal lining of the windpipe, air passages, food canal, etc., and protect these organs from physical or chemical damage.



- (b) cells forming a small tube  
e.g. a kidney tubule (see p. 132). Tubules such as this carry liquids from one part of an organ to another.



- (c) one kind of muscle cell  
Forms a sheet of muscle tissue. Blood vessels, nerve fibres and connective tissues will also be present. Contractions of this kind of muscle help to move food along the food canal or to close down small blood vessels.



- (d) cells forming part of a gland  
The cells make chemicals which are released into the central space and carried away by a tubule such as shown in (b). Hundreds of cell groups like this would form a gland like the salivary gland.

Figure 1.12 How cells form tissues

**System**

A system usually refers to a group of organs whose functions are closely related. For example, the heart and blood vessels make up the **circulatory system**; the brain, spinal cord and nerves make up the **nervous system** (Figure 1.13). In a flowering plant, the stem, leaves and buds make up a system called the shoot (p. 50).

**Organism**

An organism is formed by the organs and systems working together to produce an independent plant or animal.

An example in the human body of how cells, tissues and organs are related is shown in Figure 1.14.

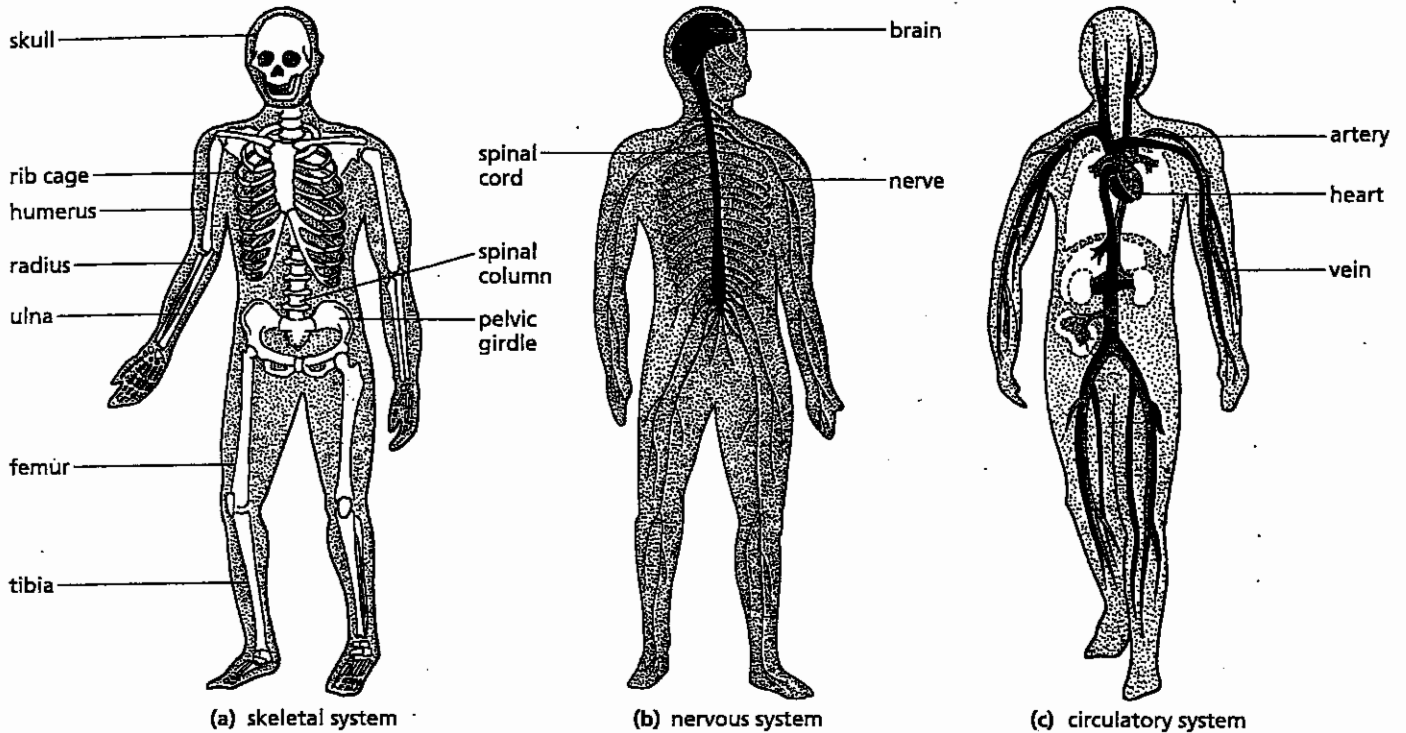
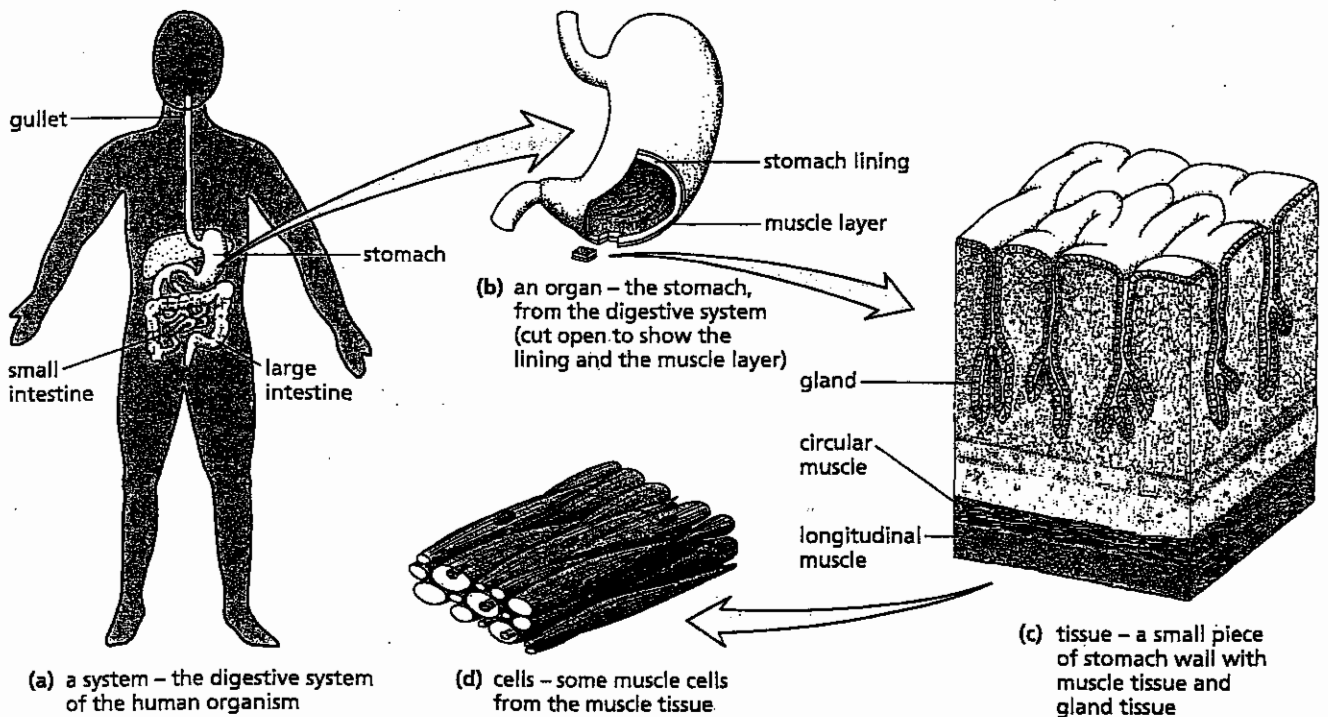


Figure 1.13 Three examples of systems in the human body



8 Figure 1.14 An example of how cells, tissues and organs are related