

Course Code: EDF 401 (P.G.C.E) 2012

UNIVERSITY OF SWAZILAND



FACULTY OF EDUCATION

DEPARTMENT OF EDUCATIONAL FOUNDATIONS AND MANAGEMENT

FINAL EXAMINATION PAPER 2011/2012

21 May, 2012

TITLE OF PAPER: School Administration

COURSE CODE: EDF 401

TIME ALLOWED: Three (3) hours

NOTES AND INSTRUCTIONS: 1. This question paper has two sections, A and B. Section A has a total of 50 marks and Section B has a total of 50 marks. The total for the paper is 100 marks.

Examiner: Mr. C. Silwane

Moderator: Prof. J.C. Perumal

THIS PAPER IS NOT TO BE OPENED UNTIL PERMISSION HAS BEEN GRANTED BY THE INVIGILATOR

SECTION A

Answer all five questions in this section.

Question 1

- (a) Explain and provide examples of what is meant by the concept of “pocket veto” in a school organisation? (6 marks)
- (b) As a principal of a school how would you improve conditions to avoid the use of “pocket veto”? (4 marks)

Question 2

The number of orphaned and vulnerable children (OVC) has increased in most schools due to the HIV/AIDS pandemic and high poverty levels.

- (a) Explain how this environmental factor may affect the activities of schools in terms of its objectives and achievements. (4 marks)
- (b) As a principal of such a school how would you improve students’ academic performance? (6 marks)

Question 3

- (a) What is the most common excuse for using one-way communication strategies such as memos by educational administrators? (4 marks)
- (b) How would you improve upward communication if you were a principal in a school? (6 marks)

Question 4

Study the figure below and answer the following questions.

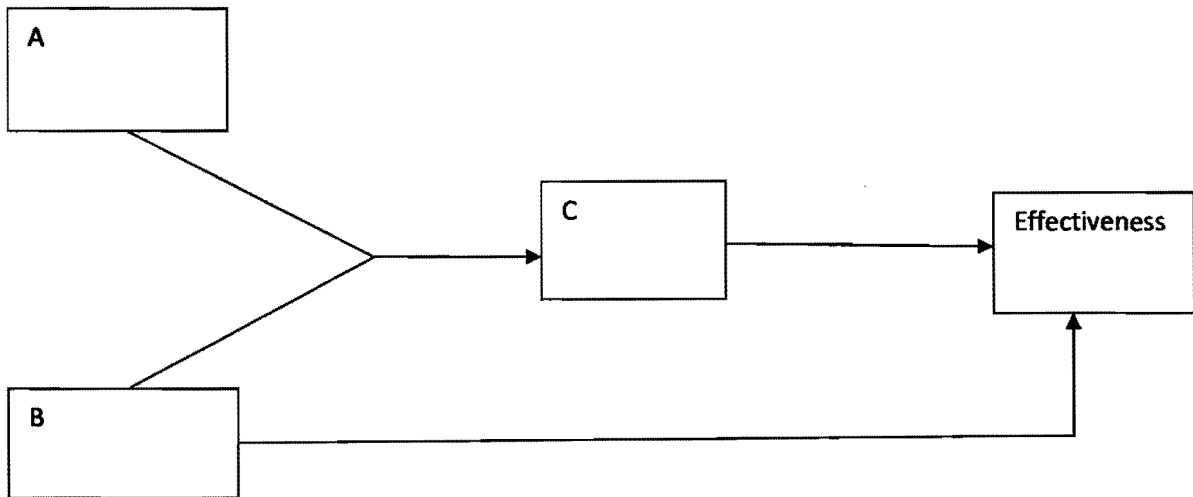

Figure: A contingency Schema for Understanding Leadership

Source: Hoy and Miskel (2008)

- (a) Complete the contingency model of leadership by indicating what each of the letters A, B and C represent. (3 marks)
- (b) Explain how this model actually works in a school situation. (4 marks)
- (c) What implications does this model have for school leadership? (2 marks)
- (d) Give one example of a contingency leadership style commonly used in schools. (1 mark)

Question 5

- (a) What do you understand by SWOT analysis and its purpose for school leadership and administration? (4 marks)
- (b) Assess the role of communication in decision-making? (4 marks)

- (c) What is the difference between *optimizing* and *satisficing* in decision-making? (2 marks)

Total [50 marks]

SECTION B

Choose two questions in this section.

Question 6

In what ways could the current bureaucratic forms of school administration be overcome to create more effective schools? [25 marks]

Question 7

- (a) Explain what is meant by organizational communication (4 marks)
- (b) Evaluate the importance of organizational communication in improving organizational efficiency and effectiveness. (21 marks)

Total [25 marks]

Question 8

- (a) Distinguish between leadership and administration. (10 marks)
- (b) Examine how an appropriate balance could be crucial in the efforts towards creating an effective organization. (15 marks)

Total [25 marks]