

UNIVERSITY OF SWAZILAND
FACULTY OF SCIENCE AND ENGINEERING
DEPARTMENT OF PHYSICS
RESIT EXAMINATION 2017/18

TITLE OF PAPER: INTRODUCTORY PHYSICS II

COURSE NUMBER: PHY102

TIME ALLOWED: THREE HOURS

INSTRUCTIONS: ANSWER ANY **FOUR** OUT OF FIVE QUESTIONS

EACH QUESTION CARRIES 25 MARKS

MARKS FOR EACH SECTION ARE IN THE RIGHT HAND MARGIN

GIVE CLEAR EXPLANATIONS AND USE CLEAR DIAGRAMS IN YOUR SOLUTIONS. MARKS WILL BE LOST WHERE IT IS NOT CLEAR HOW THE EQUATIONS USED WERE OBTAINED

THIS PAPER HAS SEVEN PAGES INCLUDING THE COVER PAGE

THE LAST PAGE CONTAINS INFORMATION THAT MAY BE USEFUL IN SOME QUESTIONS

IF IN DOUBT, RAISE YOUR HAND AND ASK

DO NOT OPEN THE PAPER UNTIL PERMISSION HAS BEEN GRANTED BY THE CHIEF INVIGILATOR

QUESTION 1

- (a) A wave is described by the following equation $x = 9.00 \sin\left(\frac{4}{3}\pi t - \frac{\pi}{2}\right)$ m. Include correct units where appropriate.
- What is the amplitude of the wave? **(1 mark)**
 - What is the angular velocity of the wave? **(1 mark)**
 - What is the phase angle of the wave? **(1 mark)**
 - Convert the wave into a sine function. **(2 marks)**
- (b) An instrument produces isotropic sound at an average power P . At a distance $r = 10.0$ m, the sound level is $= 80.0$ dB. Find the power of the sound source? **(6 marks)**
- (c) A glass rod of some length has a refractive index $n_r = 1.48$ floats halfway on water of refractive index $n_w = 1.333$. Above the rod is air. The arrangement is shown in Figure 1. A light ray enters the rod at an angle $\theta = 38.0^\circ$ with the normal from the water. Determine by calculation the path of the light ray all the way from entering the rod until it exits it. **(8 marks)**

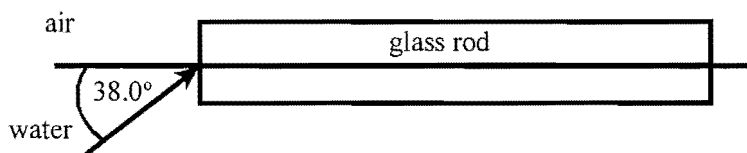

Figure 1.

- (d) An object is placed 14.0 cm in front of a lens of focal length $f = 12.0$ cm.
- Find the image distance. **(3 marks)**
 - Determine the magnification. **(2 marks)**

QUESTION 2

Three point charges $q_1 = 6.00 \mu\text{C}$ and $q_2 = -4.00 \mu\text{C}$ and $q_3 = 8.00 \mu\text{C}$ are located at the corners of a triangle as shown in Figure 2. Point P is along the x -axis directly below q_3 .

- i. Use a diagram to determine the unit vectors $\hat{r}_{1,3}$ and $\hat{r}_{2,3}$ for the directions from q_1 to q_3 , and q_2 to q_3 , respectively. **(4 marks)**
- ii. Find the force on q_3 due to q_1 in vector form. **(3 marks)**
- iii. Find the force on q_3 due to q_2 in vector form. **(3 marks)**
- iv. Find the total force vector on q_3 due to the other two charges. **(2 marks)**
- v. Find the electric field vector at the location of q_3 due to q_1 . **(2 marks)**
- vi. Find the electric field vector at the location of q_3 due to q_2 . **(2 marks)**
- vii. Find the total electric field vector at the position of q_3 due to the other two charges. **(2 marks)**
- viii. Use the total electric field vector to obtain the force on q_3 due to the other two charges. **(2 marks)**
- ix. With what charge must q_3 be replaced by to make the potential at point P to be 0.00 V ? **(5 marks)**

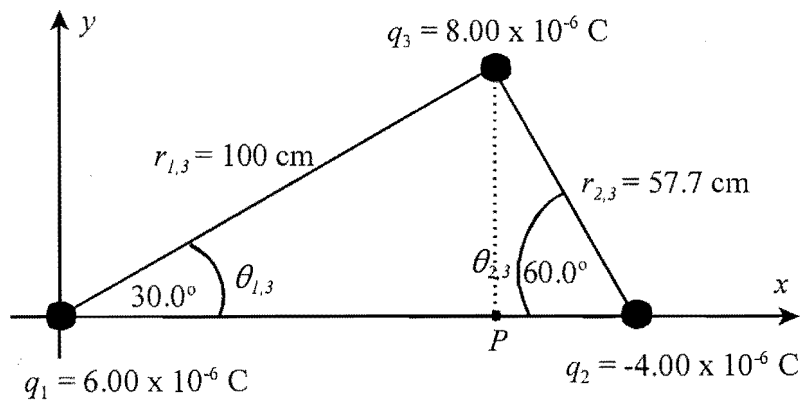

Figure 2.

QUESTION 3

- (a) In the circuit shown in Figure 3, use Kirchoff's laws and a diagram to obtain any three equations that can enable you to determine the currents I_1 , I_2 and I_3 given all the other quantities. (*Do not solve for the currents*) **(6 marks)**

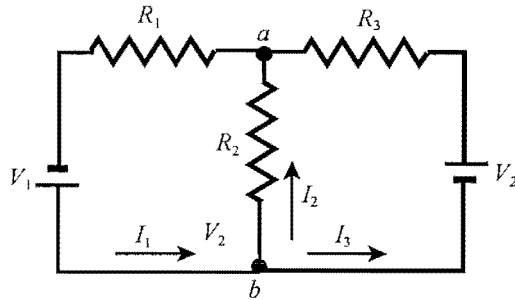

Figure 3.

- (b) Consider the network shown in Figure 4.
- Find the effective resistance between points a and b (R_{ab}). **(2 marks)**
 - Find the effective resistance between points b and c . (R_{bc}). **(3 marks)**
 - Find the effective resistance of the circuit R_{eff} . **(1 mark)**
 - What is the total current through the network? **(1 mark)**
 - What is the voltage drop V_{ab} between junctions a and b ? **(2 marks)**
 - Determine the current through each of the resistors R_1 and R_2 . **(4 marks)**

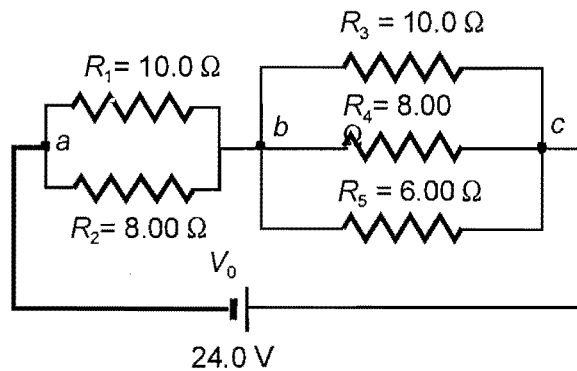

Figure 4.

- (c) A galvanometer of internal resistance 60.0Ω requires a current of 0.500 mA for full scale deflection, and is to be used as a 0.100 A ammeter and.
- Make a sketch that illustrates how the student can convert the galvanometer into an ammeter. **(2 marks)**
 - Find the value of the resistor required to turn the galvanometer into a 25.0 V voltmeter. **(4 marks)**

QUESTION 4

- a) A $8.00 \mu\text{F}$ capacitor is charged with a 12.0 V battery through a resistor R .
- What is the total charge in the capacitor after one timeconstant? **(3 marks)**
 - Find the total energy stored in the capacitor after one timeconstant. **(2 marks)**
 - Suppose the capacitor is then discharged through the resistor R . Find the energy remaining in the capacitor after one time const. **(2 marks)**
- b) A horizontal rod carrying a current $I = 2.00 \text{ A}$ along its length $l = 50.0 \text{ cm}$ is placed in a magnetic field of magnitude $B = 3.60 \text{ T}$ in to the page. The direction vectors (unit vectors) are as shown in Figure 5 on the right. The magnetic force pulls the rod upward, while the gravitational force pulls the rod downward.
- Find the direction of the current in the rod. **(4 marks)**
 - What is the force due to the magnetic field on the rod? **(2 marks)**
 - Find the mass of the rod. **(2 marks)**

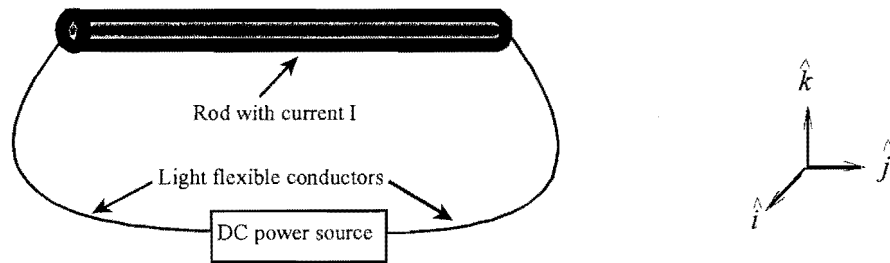

Figure 5.

- c) Particles of charge q and mass m are accelerated from rest through a potential difference ΔV .
- Find an expression for the velocity v of the charged particles in terms of m , q and ΔV . **(3 marks)**
 - The accelerated particles are then subjected to a magnetic field B perpendicular to their direction of motion. Find an expression for the radius of curvature of the particles in the magnetic field in terms of B , m , q and ΔV . **(7 marks)**

QUESTION 5

- a) An independent power producer generates 20.0 MW of electricity at a peak voltage of 9.50 kV. Determine the rms voltage and current for the system. **(5 marks)**
- b) A step-down transformer is used for recharging a battery. The turns ratio of primary to secondary in the transformer is 24.4: 1 and is used with a 220 V (rms) household service. The transformer draws a current of 50.0 mA rms from the house outlet.
- What is the voltage supplied to the battery? **(2 marks)**
 - What is the current supplied to the battery? **(2 marks)**
 - How much does it cost to charge the battery each time, if it takes 12.0 hours per charge, assuming that electricity costs 178 cents per kilowatt-hour **(3 marks)**
- c) An inductor ($l = 500$ mH), a capacitor ($C = 3.48$ μ F) and a resistor ($R = 470$ Ω) are connected in to a 50.0 Hz power source with a peak voltage of 450 V.
- Find the impedance of the network. **(5 marks)**
 - Determine the peak current I_{\max} . **(2 marks)**
 - Find the phase angle and state with justification whether the current lags or leads the voltage. **(4 marks)**
 - What is the power consumed by the network? **(2 marks)**

DATA SHEET

General data

Air refractive index = 1.00

Avogadro's number $N_A = 6.022 \times 10^{23} \text{ mol}^{-1}$

Boltzmann's constant $k_B = 1.38 \times 10^{-23} \text{ J/K}$

Density of mercury = $1.36 \times 10^4 \text{ kg/m}^3$

Gas constant $R = 8.314 \text{ J/(mol.K)}$

Gravitational acceleration $g = 9.80 \text{ m/s}^2$

Standard atmospheric pressure = $1.013 \times 10^5 \text{ Pa}$

Speed of light in vacuum $c = 2.9978 \times 10^8 \text{ m/s}$

Speed of sound in air $v_s = 343 \text{ m/s}$

Stefan-Boltzmann constant $\sigma = 5.67 \times 10^{-8} \text{ W/(m}^2\text{.K}^4)$

Threshold of hearing $I_0 = 10^{-12} \text{ W/m}^2$

Universal gravitational constant $G = 6.67 \times 10^{-11} \text{ N. m}^2\text{/kg}^2$

1 calorie = 1 c = 4.186 J

1 food calorie = 1 Calorie = 1C = 10^3 calories = $4.186 \times 10^3 \text{ J}$

Water data

$c(\text{water}) = 4186 \text{ J/(kg.K)}$

$c(\text{ice}) = 2090 \text{ J/(kg.K)}$

$c(\text{steam}) = 2079 \text{ J/(kg.K)}$

$L_f(\text{ice}) = 3.33 \times 10^5 \text{ J/kg}$

$L_v(\text{water}) = 2.260 \times 10^6 \text{ J/kg}$

$\rho(\text{water}) = 1000 \text{ kg/m}^3$

refractive index $n_w = 1.333$

Electricity and nuclear data

Alpha particle mass = $6.644657 \times 10^{-27} \text{ kg}$

Charge of an electron = $-1.6 \times 10^{-19} \text{ C}$

Charge of a proton = $+1.6 \times 10^{-19} \text{ C}$

Coulomb's constant $k_e = 8.9875 \times 10^9 \text{ Nm}^2\text{/C}^2$

Deuteron mass = $3.343583 \times 10^{-27} \text{ kg}$

Electron mass, $m_e = 9.109 \times 10^{-31} \text{ kg}$

Neutron mass $m_n = 1.675 \times 10^{-27} \text{ kg}$

Proton mass, $m_p = 1.673 \times 10^{-27} \text{ kg}$

1 atomic mass unit = 1 amu = 1 u = $1.66 \times 10^{-27} \text{ kg}$

$\epsilon_0 = 8.85 \times 10^{-12} \text{ C}^2\text{(N.m}^2)$

1 Ci = 3.7×10^{10} decays/s

1Bq = 1 decay/s